

BRIDEX

FE Fuji Electric
Innovating Energy Technology

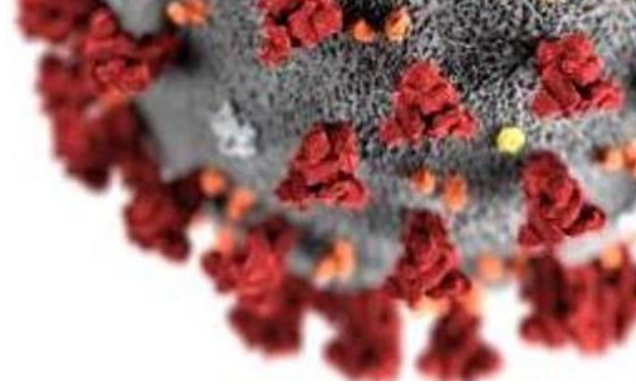

COVID-19: FeverCheck++

FACIAL RECOGNITION & BODY TEMPERATURE SCREENING



- ✓ HIGH-PERFORMANCE CPU
- ✓ FACE RECOGNITION
- ✓ SUPPORT MASK RECOGNITION
- ✓ CONTACTLESS TEMPERATURE MEASUREMENT



PRECISE IDENTIFICATION



ABNORMAL ALARM



INFRARED SCANNING



MASK RECOGNITION



VOICE ANNOUNCEMENTS



QUICK RESPONSE



TEMPERATURE DETECTION

 **SafeEntry**

FEVERCHECK++

FACIAL RECOGNITION & BODY TEMPERATURE SCREENING

Non-contact infrared thermometry temperature measurement for detected elevated temperatures is mandatory for reducing the spread of Covid-19. This is critical to re-open or keep open factories, buildings, construction sites, businesses or facilities of any kind.

Features

- ★ Contactless High Precision thermal imaging module
- ★ Temperature Detection range 35°C ~ 42 °C with $\pm 0.3^{\circ}\text{C}$ precision
- ★ Support Body Temperature and photo overlay
- ★ Support Mask Detection with audio warning alarm
- ★ Built-in Face recognition algorithm
- ★ 50,000 Faces in one device
- ★ Ultra-Fast (100 ms) identification
- ★ 8inch HD LCD display
- ★ Automatic Snapshot of visitor's face with temperature record and time stamp
- ★ Multiple Hardware Interface
Integrated 100M Ethernet interface, audio interface, Wiegand interface & relay interface
- ★ Support Wiegand Protocol with direct access control to various door systems
- ★ Programmable Local Relay Output
- ★ Low Power Consumption as low as 5 watts
- ★ Excellent Environmental Adaptability to both low light conditions and strong backlight with automatic face exposure
- ★ Support the secondary development of device-side application software
- ★ Export Attendance Records of employees' temperature & time information in excel format
- ★ Visitor Log with Face, Temperature & Time Stamp can be exported in excel format as well
- ★ Safe Entry Compatible

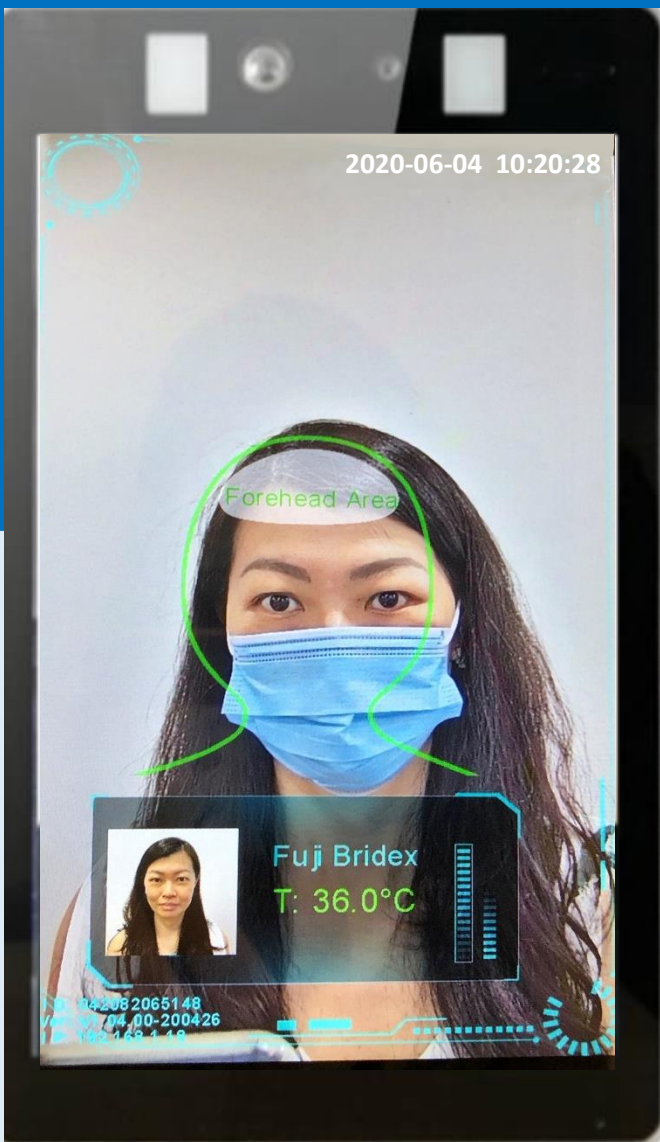

Product Information

8-inch Facial Recognition + Body Temperature Smart Measurement Display

Scope of Application:



Technical Specifications:

Model		Fuji Bridex FeverCheck++		
		FB FC++01		
Display		8-inch LCD		
Thermal	Sensor	Thermal imaging infrared temperature sensor		
	Temperature	Range: 35~42°C, Precision: ±0.3°C		
	Detect distance	0.4m~0.7m		
Visible Parameters	Lens	focal length 1.8mm, Field of View: 118°		
	Mini illum	0.005Lux@F1.2 color mode		
	Dynamic range	≥120dB		
	S/N Ratio	≥46dB (AGC OFF)		
	Exposure mode	Program mode (customizable shutter interval), shutter mode (1/5 - 1/20,000s) support for slow shutter		
	White balance	Auto, indoor, outdoor, sodium lamp mode, manual		
	Digital noise reduction	Support DNR,3DNR		
	Day and night mode	Fixed color		
Image and Compression	Video compression	H.265 Main Profile / H.264 High profile / M-JPEG		
	Max resolution	1920x1080@30fps		
	Resolution	Main stream	1920x1080、1280x960、1280x720、720x576	
		Substream	640x480、352x288、320x240、176x144	
		MJPEG	1920x1080、1280x720、closed	
	Output bit rate	(CBR or VBR), Bitstream setting range: 32Kbps~10Mbps		
	Audio compression	G711, PCM		
Character overlay	Support channel name, date and time overlay, adjustable overlay position;			
AI	Number of face bases	50,000 sheets		
	Recognition speed	≤300ms		
	Live detection	Support		
	Mask detection	Support		
	Body temperature	Support		
Interface	Power	DC12V		
	Network	1ch10/100BaseT Ethernet RJ45 interface		
	Wiegand	1ch Wiegand output interface		
	Switch	1ch relay output		
	SD card	Up to 128G		
	MIC	Built-in		
	Audio	Built-in 2ch audio output		



Technical Specifications:

Physical Characteristics	Working Humidity	Face Recognition -10~50°C BodyTemperatureMeasurement:15~35°C
	Working Humidity	0%-90% RH
	Power Consumption	5W
	Size	215x125x20mm
	Weight	<1kg

Accessories:

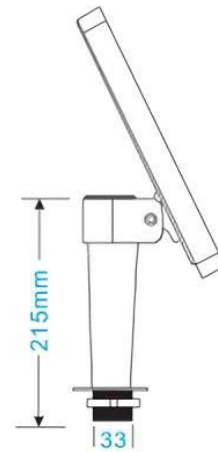
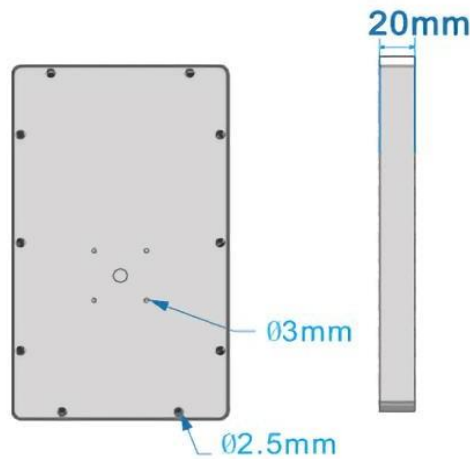

Dashboard:

ID	name	Gender	Age	List the type	
42	Fuji Bridex	Woman	0	white list	
44	Fuji Bridex 1	Man	0	white list	
45	Fuji Bridex 2	Man	0	white list	
46	Fuji Bridex 3	Woman	0	white list	
47	Fuji Bridex 4	Woman	0	white list	
48	Fuji Bridex 5	Man	0	white list	

Find out MORE!

FUJI BRIDEX PTE LTD
541 Yishun Industrial Park A,
Singapore 768764

+65 6756 0833

sales@bridex.fujielectric.com

<https://bridex.fujielectric.com/>